

USER'S MANUAL

VUT 350 H

VUT 500 H

VUT 530 H

VUT 600 H

VUT 1000 H

VUT 2000 H

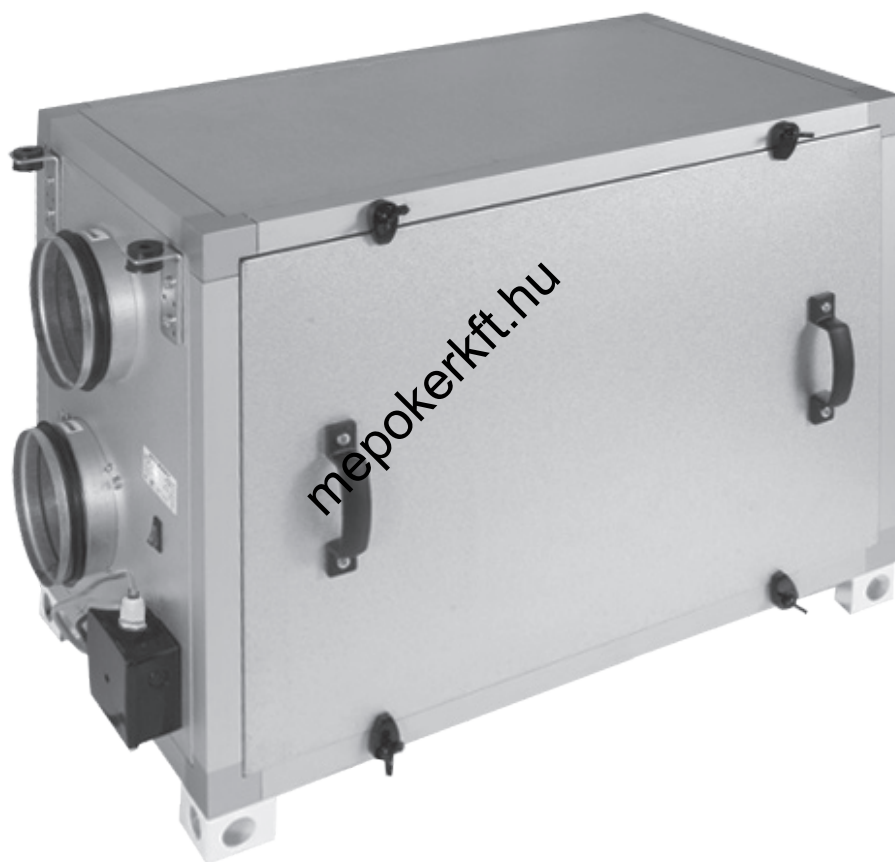

HEAT RECOVERY AIR HANDLING UNIT

CONTENTS

Safety requirements	3
Introduction	5
Use	5
Delivery set	5
Designation key	5
Technical data	6
Unit design and operating logic	8
Mounting and set-up	9
Condensate drainage	10
Connection to power mains	11
Unit control	12
Maintenance	13
Fault handling	14
Storage and transportation rules	14
Manufacturer's warranty	15
Acceptance certificate	16
Seller information	16
Connection certificate	16
Warranty card	17

mepokerkft.hu

SAFETY REQUIREMENTS







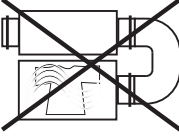

- Read the user's manual carefully prior to the operation and installation of the VUT ... H heat recovery air handling unit.
- Fulfil the user's manual requirements as well as the provisions of all the applicable local and national construction, electrical and technical codes and standards.
- The warnings contained in the user's manual must be considered most seriously since they contain vital personal safety information.
- Failure to follow the safety requirements may result in an injury or unit damage.
- Read the manual carefully and keep it as long as you use the unit.
- While transferring the unit control the user's manual must be turned over to the receiving operator.

Symbol legend used in the manual:

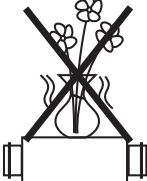
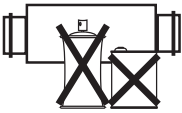
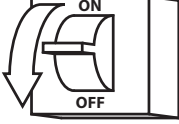
	WARNING!
	DO NOT!

UNIT MOUNTING AND OPERATION SAFETY PRECAUTIONS

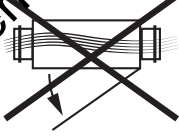
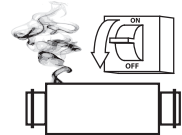
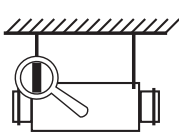
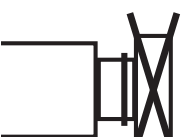
	The unit must be disconnected from power supply prior to any installation or repair operations.		The unit must be grounded!
	The unit must not be operated outside the temperature range stated in the user's manual and in aggressive or explosive environments.		Do not use damaged equipment or conductors to connect the unit to power mains.
	While installing the unit follow the safety regulations specific to the use of electric tools.		Unpack the unit with care.
	Do not change the power cable length at your own discretion. Do not bend the power cable. Avoid damaging of the power cable.		Do not position any heating devices or other equipment in close proximity to the unit power cable.

	<p>Do not touch the unit controls with wet hands. Do not carry out the unit maintenance with wet hands.</p>		<p>Use the unit only as intended by the manufacturer. Do not connect a clothes dryer or other similar equipment to the unit or the ventilation system.</p>
	<p>Do not wash the unit with water. Protect the unit electric parts from water ingress.</p>		<p>Do not put any water containers on the unit, i.e. flower vases.</p>
	<p>Keep combustible gases and inflammable products away from the unit.</p>		<p>Disconnect the unit from power supply prior to maintenance.</p>
	<p>Do not let children operate the unit.</p>		<p>Do not damage the power cable while operating the unit. Do not put any objects on the power cable.</p>
	<p>Do not sit on the unit and do not put any objects on it.</p>		<p>Do not open the operating unit.</p>
	<p>In case of unusual sounds, smell of smoke disconnect the unit from power supply and contact the service centre.</p>		<p>During a long-term operation of the unit periodically check the mounting for reliability.</p>
	<p>Do not block the air duct when the unit is on.</p>		<p>Do not let air flow from the unit be directed to the open flame devices or candles.</p>

■ INTRODUCTION

This user's manual includes technical description, operation, installation and mounting guidelines, technical data for the VUT ... H heat recovery air handling unit, hereinafter referred to as "the unit".

■ USE

- Due to the ability to save heating energy by means of energy recovery the unit is an important energy saving element used in the buildings and premises. The unit is a component part and is not designed for stand-alone operation.
- The unit is designed to provide permanent controlled air exchange by means of mechanical ventilation in houses, offices, hotels, cafés, meeting halls and other mechanically ventilated premises as well as utilization of extract air heat energy to warm up supply purified air.
- The unit is designed for extended periods of continuous operation without disconnection from the power mains.
- Transported air must not contain any flammable or explosive mixtures, evaporation of chemicals, sticky substances, fibrous materials, coarse dust, soot and oil particles or environments favourable for the formation of hazardous substances (toxic substances, dust, pathogenic germs).



THE UNIT IS NOT INTENDED TO BE USED BY CHILDREN, PHYSICALLY OR MENTALLY DISABLED PERSONS, PERSONS WITH SENSORY DISORDER, PERSONS WITH NO APPROPRIATE QUALIFICATION. ALL OPERATIONS WITH THE UNIT MUST BE PERFORMED ONLY BY PROPERLY QUALIFIED PERSONNEL AFTER THE APPROPRIATE SAFETY BRIEFING. THE UNIT INSTALLATION SITES MUST PREVENT ACCESS BY UNATTENDED CHILDREN.

■ DELIVERY SET

■ Unit	1 item
■ Speed switch	1 item
■ User's manual	1 item
■ Packing box	1 item

■ DESIGNATION KEY

VUT X H

Spigot orientation

H - horizontal

Air capacity [m³/h]

350, 500, 530, 600, 1000, 2000

Unit type

VUT - ventilation with heat recovery

mepokerkft.hu

■ TECHNICAL DATA

The air-handling unit is intended for operation in closed spaces under ambient air temperatures from +10 °C to +50 °C.

Hazardous parts access and water ingress protection rating:

- IP 44 for the unit motors;
- IP 22 for the assembled unit connected to the air ducts.

The unit design is constantly being improved, so some models can slightly differ from those ones described in this manual.

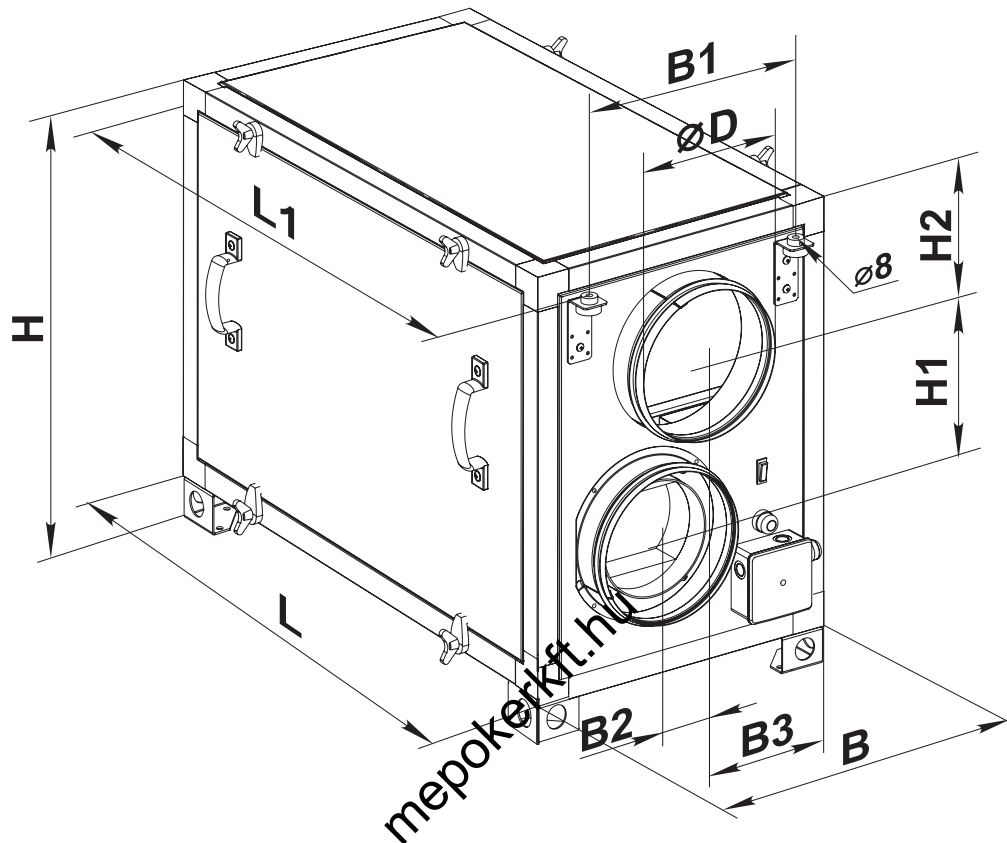

Unit overall and connecting dimension

Model	Dimensions [mm]									
	ØD	B	B1	B2	B3	H	H1	H2	L	L1
VUT 350 H	124	416	300	54	207	603	230	148	722	768
VUT 500 H	149	416	300	54	207	603	230	148	722	768
VUT 530 H	159	416	300	54	207	603	230	148	722	768
VUT 600 H	199	416	300	54	207	603	230	148	722	768
VUT 1000 H	248	548	496	60	213	794	290	200	802	850
VUT 2000 H	313	846	796	235	588	968	360	246	1000	1050

Unit technical data

Parameter	VUT 350 H	VUT 500 H	VUT 530 H	VUT 600 H	VUT 1000 H	VUT 2000 H
Unit supply voltage, 50 Hz [V]	1~ 230					
Total unit power [W]	260	300	300	390	820	1300
Total unit current [A]	1,2	1,32	1,32	1,72	3,6	5,68
Max. air capacity, m ³ /h	350	500	530	600	1200	2200
PRM	1150	1100	1100	1350	1850	1150
Sound pressure level at 3 m distance [dB(A)]	24-45	28-47	28-47	32-48	60	65
Transported air temperature [°C]	from -25 up to +55	from -25 to +50		from -25 to +55	from -25 to +40	
Casing material	aluzinc					
Insulation	25 mm mineral wool			50 mm mineral wool		
Extract filter	G4					
Supply filter	F7				G4(F7)*	G4(F7)*
Replaceable filter G4*	SF VUT 350-600 H G4				SF VUT 1000 H G4	SF VUT 2000 H G4
Replaceable filter F7*	SF VUT 350-600 H F7				SF VUT 1000 H F7	SF VUT 2000 H F7
Summer block*	VL VUT 350 H	VL VUT 500-600 H			VL VUT1000 H	VL VUT2000 H
Connected air duct diameter [mm]	Ø125	Ø150	Ø160	Ø200	Ø250	Ø315
Weight [kg]	45	49	49	54	85	96
Heat recovery efficiency, %	up to 78	up to 88	up to 88	up to 85	up to 88	up to 87
Heat exchanger type	cross flow					
Heat exchanger material	Aluminium					

*extra summer blocks and sets of replaceable filters are optional extras and can be purchased separately.

mepokerkft.hu



UNIT DESIGN AND OPERATING LOGIC

- Unit operation logic: warm stale extract air from the room flows to the unit, where it is filtered, then air flows through the heat exchanger and is exhausted outside by the extract fan. Clean cold air from outside is moved to the supply filter. Then filtered air flows through the heat exchanger and is moved to the room with the supply fan.
- Heat energy of warm extract air is transferred to clean intake fresh air from outside and warms it up. Heat recovery minimizes thermal energy losses and intake air heating expenses in cold seasons.
- The thermostat relay installed in the unit casing provides frost protection of the heat exchanger during cold seasons.
- The difference between the intake and extract air temperatures results in condensation formation in the heat exchanger during the air-handling unit operation. The condensate is collected in the condensate drain pan and is extracted from the unit via the drain pipe.
- The air handling unit is equipped with specially sealed service panels for repair and maintenance operations. The terminal box on the side panel incorporates a terminal block. Power and ground cables are connected to the terminal block through the sealed electric lead-ins.

VUT 350 ... 600 H

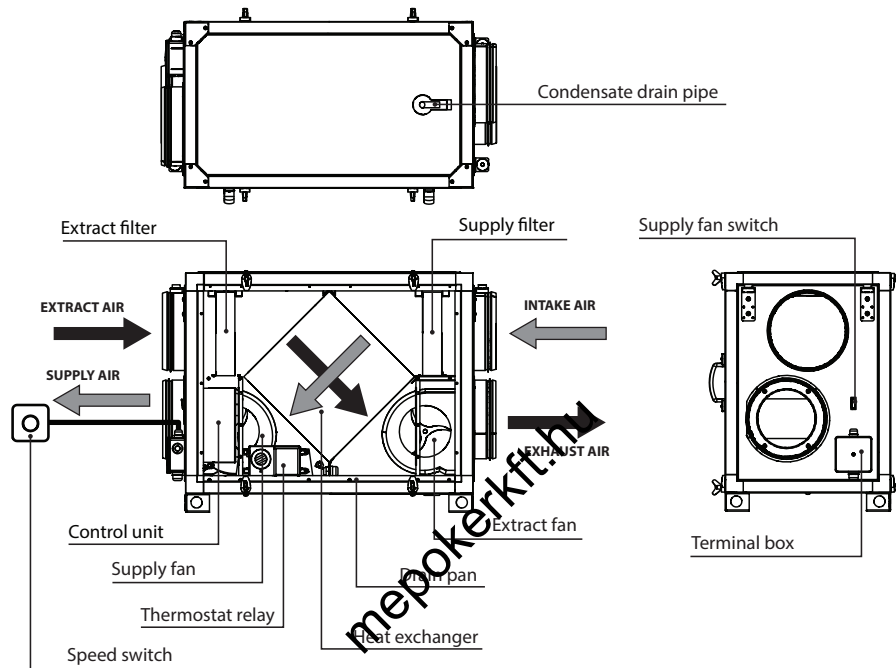

VUT 1000 ... 2000 H

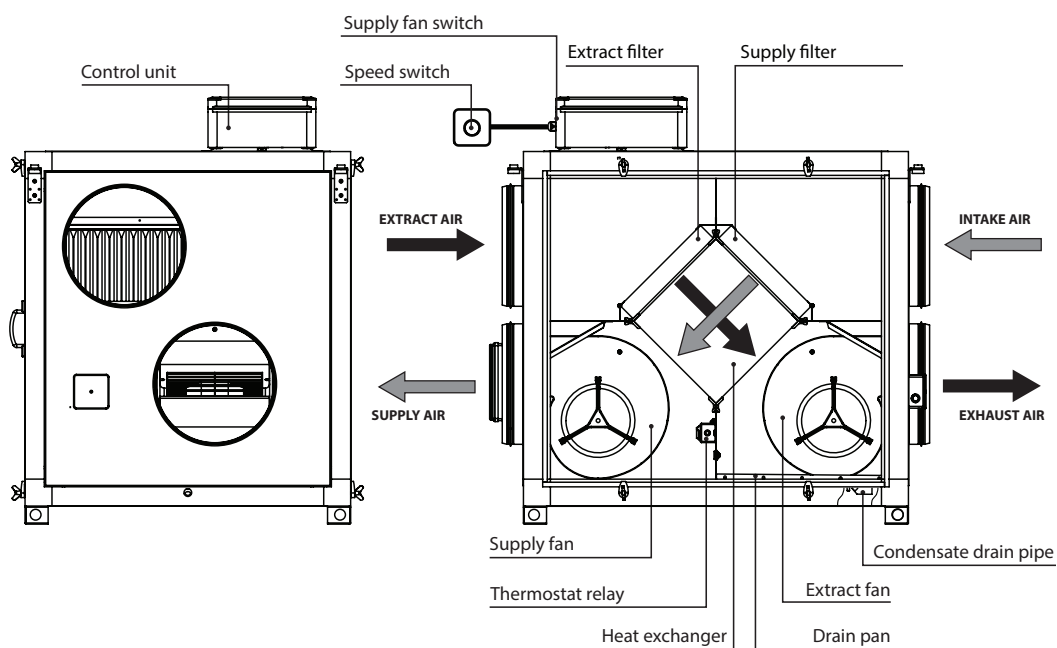

■ MOUNTING AND SET-UP

The unit may be suspended on threaded rods that are fixed inside a dowel or may be rigidly fixed on a horizontal plane. While mounting the unit provide enough access for maintenance or repair work.

Unit ceiling mounting

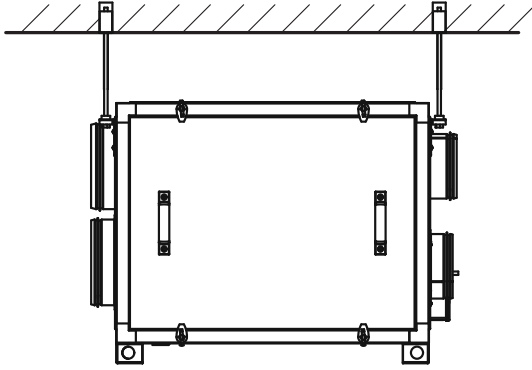

Unit floor mounting

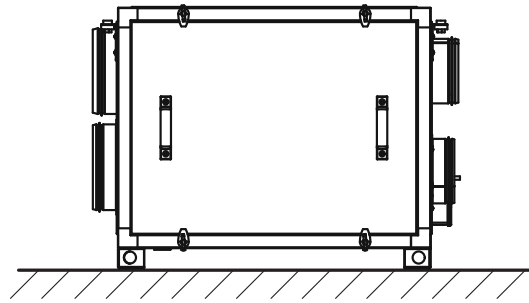

Safety precautions:

- In a floor-mounted configuration the unit must be provided with a rigid and stable base structure (the technical characteristics and unit weight specifications are given in the technical parameters table).
- To fix the unit to the floor use anchor bolts. Make sure that the base structure is capable of sustaining the unit weight or reinforce the mounting location.
- To fix the unit to the ceiling use anchor bolts. The insufficient strength of fastening system causes resonance with the vibrations generated by the unit which, in turn, results in unwanted noise.
- Therefore, arrange a maintenance area and an inspection hole for air filter, heat exchanger and fan service in consideration of the unit overall dimensions (see page 6). Provide an inspection hole for each unit.
- Install M8 anchor bolts before proceeding with the installation. Insert the anchor bolt into the ceiling mounting opening and secure it with nuts and washers.
- Prior to commencing the installation check the unit casing for any left-over foreign objects such as plastic film or paper.
- The lack of length in the anchor bolts used for the unit installation may cause abnormal noise resulting from resonance with the natural vibrations of the ceiling.
- If the abnormal noise is generated at the spiral air duct joint replace the spiral air duct with a flexible one to prevent resonance.
- Flexible anti-vibration connectors are another alternative for dealing with resonance. To ensure the best performance of the unit provide a straight duct section on both sides of the unit at least 1 m in length.
- The unit must be equipped with a grille with the minimum cell diameter of 12.5 mm or a similar protective device preventing free access to the fans.

■ P3-1-300 MECHANICAL SPEED SWITCH INSTALLATION:



MAKES SURE THAT THE SWITCH IS INTACT. DO NOT USE DAMAGED SWITCHES. DO NOT MOUNT THE SWITCH ONTO AN UNEVEN SURFACE. WHILE TIGHTENING THE SELF-TAPPING SCREWS DO NOT APPLY EXCESSIVE FORCE TO PREVENT SWITCH CASING DEFORMATION.

The speed switch is part of the unit delivery set and is factory-connected to the terminal block located inside the unit control box according the wiring diagram (see Fig. "Wiring diagram").

- Route all the necessary cables and wires to the switch fitting location.
- Install the mounting box (not included in the delivery set) into the wall.
- Disassemble the switch and disconnect the connected wires.

- Connect the switch according to the wiring diagram (see page 12).
- Place the executive part of the switch into the mounting box.
- Secure the executive part of the switch by means of two screws (included in the delivery set).
- Cover the executive part of the switch with the decorative front panel and secure the panel by pressing the panel surface over the latches until they snap in place.

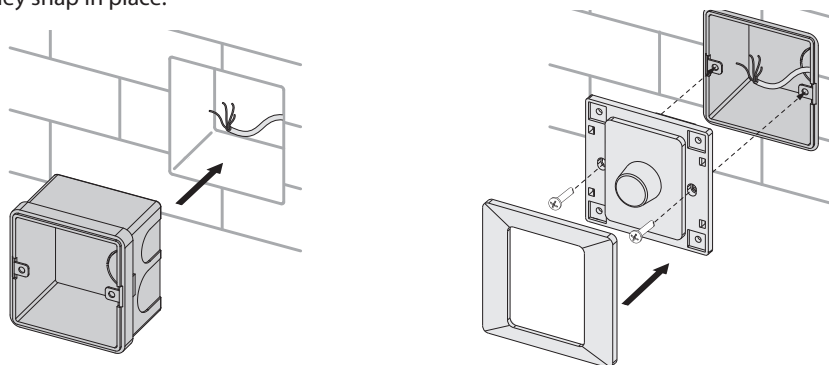

■ CONDENSATE DRAINAGE



DO NOT CONNECT SEVERAL DRAIN PIPES FROM SEVERAL AIR HANDLING UNITS TO ONE U-TRAP! DIRECT CONDENSATE DRAINAGE OUTSIDE WITHOUT CONNECTION TO SEWAGE SYSTEM IS NOT ALLOWED.

The unit must be connected to a drainage system. Connect the drain pipe, the U-trap (not included in the standard delivery set) and the sewerage system with metal, plastic or rubber pipes. The pipes must be installed at the minimum downward gradient of 3°. The recommended U-trap sizes are given in the table:

Unit model	Minimum dimensions, [mm]	
	A	B
VUT 350 ... 600 H	120	60
VUT 1000 ... 2000 H	200	110

Before starting the unit fill the system with water and check that the U-trap is always filled with water. Make sure that the water drainage is correct. Wrong connection to sewage system may result in condensate accumulation inside the unit.

The condensate drainage system is designed for operation at the ambient temperature above 0 °C!

If the ambient temperature is below 0 °C, the condensate drainage system must be heat insulated and pre-heated.

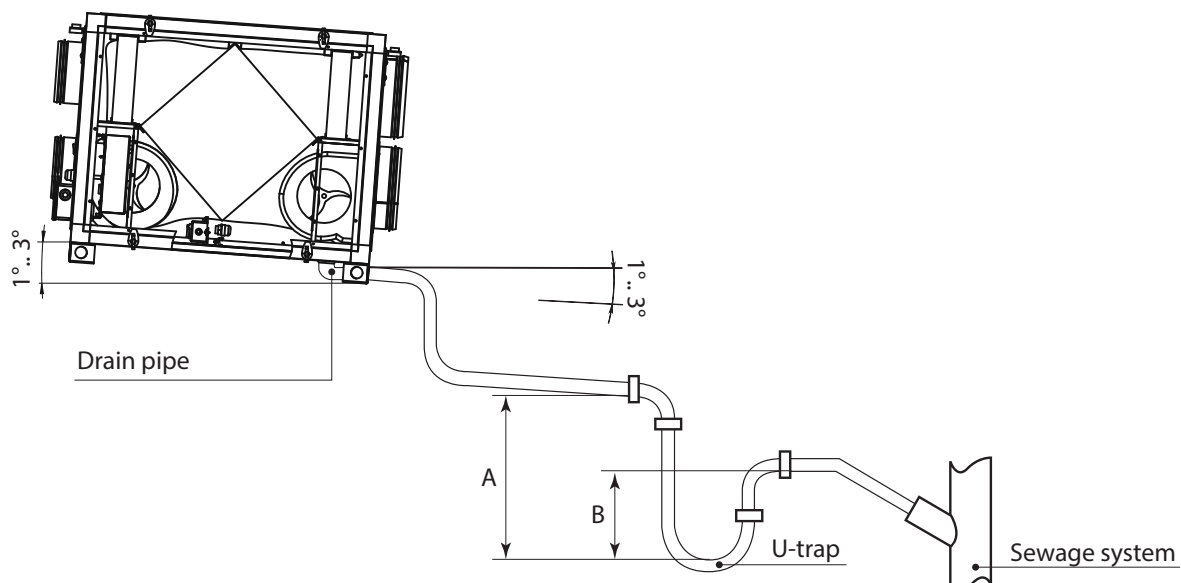

■ CONNECTION TO POWER MAINS



THE POWER MAINS CONNECTION SHALL ONLY BE PERFORMED BY QUALIFIED PERSONNEL AFTER CAREFUL READING OF THIS USER'S MANUAL. CONNECT THE UNIT TO AN AC POWER SUPPLY WITH THE VOLTAGE CORRESPONDING TO THE VALUE SPECIFIED IN THE TABLE OF TECHNICAL DATA. MAKE SURE THAT THE CABLE IS NOT PINCHED. DO NOT SWITCH ON THE UNIT IF THE CABLE IS DAMAGED. NEVER REMOVE THE PLUG FROM THE POWER OUTLET WITH WET HANDS. DO NOT PULL ON THE ELECTRIC CABLE. DISCONNECT THE UNIT FROM POWER SUPPLY PRIOR TO ANY OPERATIONS WITH THE UNIT! THE RATED ELECTRICAL PARAMETERS OF THE UNIT ARE GIVEN ON THE MANUFACTURER'S LABEL. ANY TAMPERING WITH THE INTERNAL CONNECTIONS IS PROHIBITED AND WILL VOID THE WARRANTY.

The unit is rated for connection to single-phase AC 230 V / 50 Hz power mains. The connection must be made using durable, insulated and heat-resistant conductors (cables and wires). The external power input must be equipped with an automatic circuit breaker built into the stationary wiring to disconnect all the power mains phases. The automatic circuit breaker position must ensure free access for emergency shutdown of the unit.

Recommended rated current of the circuit breaker depending on the unit model:

Unit model	Rated current of the circuit breaker [A]
VUT 350 H	1,6
VUT 500 H	
VUT 530 H	
VUT 600 H	2
VUT 1000 H	6
VUT 2000 H	10

The conductor cross section is 0.75 mm². The given conductor section value is tentative. In practice the conductor selection shall be based on the maximum permissible wire heating depending on the wire type, its insulation, length and installation method (i.e. overhead, in pipes or inside the walls).

Use copper wires only.

The unit must be grounded!



VUT ... H air-handling units must be connected to the power mains in accordance with the wiring diagram and the terminal designations given inside the terminal box or the control unit:

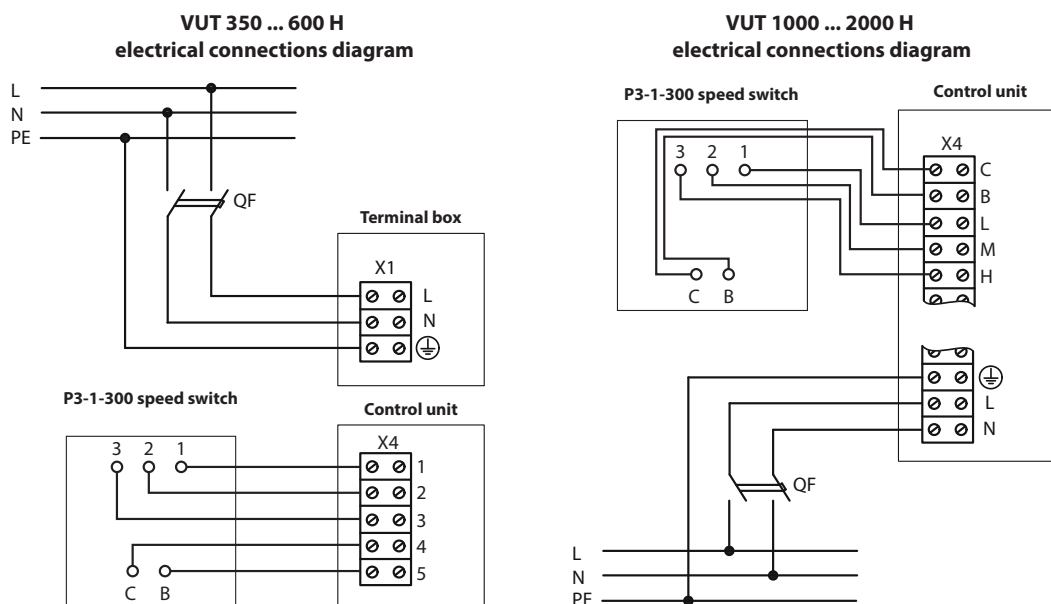

All the control and power supply wires must be connected in accordance with the terminal markings. The supply mains wires are attached to the respective clamps of X1 terminal block (VUT 350 ... 600 H) or X4 (VUT 1000 ... 2000 H).

The automatic circuit breaker with a thermal magnetic trip protects the unit circuit against overloading and shorting.

P3-1-300 speed switch is used to activate and deactivate the unit as well as to select the desired operation speed.

The unit is equipped with a built-in heat exchanger protection system to prevent its freezing in the cold season. If the heat exchanger freezing becomes imminent a thermostat relay interrupts the supply fan circuit. After the supply fan shuts down automatically the heat exchanger is warmed up by the stream of warm air from the extract fan. When the heat exchanger has thawed the supply fan activates automatically. The recommended operating value for the thermostat relay in the absence of a duct heater in the ventilation system plenum segment is $+3^{\circ}\text{C}$ (factory setting). To set the thermostat operation temperature turn the control knob until reaching the desired value.

Pressing the designated keyswitch also turns the supply fan off. The keyswitch is located either on the side panel (VUT 350 ... 600 H) or on the control unit (VUT 1000 ... 2000 H).

The terminal designation diagram is given on the sticker inside the terminal box or the control unit. The unit terminal screw markings comply with the respective ones on the electrical diagram.

The cables are routed into the terminal box through a sealed lead-in for electrical hazard class compliance.

UNIT CONTROL

The unit is controlled by means of P3-1-300 speed switch.

Make sure to install the switch in a convenient location. The speed switch is part of the unit delivery set and is factory-connected to the terminal block located inside the unit control box according the wiring diagram (see Fig. "Wiring diagram").

- To engage the desired speed turn the speed control knob clockwise into one of the three positions available:

- 1 — Speed 1;
- 2 — Speed 2;
- 3 — Speed 3.

- To switch off the unit turn the speed control knob counterclockwise until reaching the OFF position.

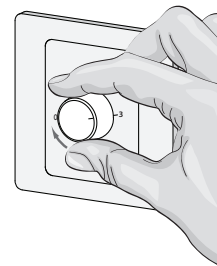
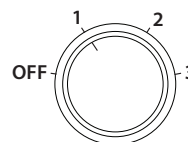

■ MAINTENANCE

The unit must undergo technical maintenance 3 to 4 times a year. Maintenance includes general cleaning of the unit and the following operations:

1. Filter maintenance (3-4 times per year).

Dirty filters increase air resistance in the system and reduce supply air volume. The filters require cleaning not less than 3-4 times per year. Clean the filters with a vacuum cleaner or replace them. For new filters contact your Seller.

2. Heat exchanger maintenance (once per year).

Some dust may accumulate on the heat exchanger block even in case of regular maintenance of the filters. To maintain the high heat exchange efficiency, regular cleaning is required. To clean the heat exchanger pull it out, flush the heat exchanger with warm detergent solution. After cleaning install the dry heat exchanger back to the unit.

To remove the filters and the heat exchanger proceed as follows:

- make sure the unit is disconnected from power mains;
- undo four clips that fix the front panel from the service side (refer to para. 1), remove the panel (refer to para. 2).
- remove the filters (refer to para. 3).
- remove the heat exchanger (refer to para. 4).

1.

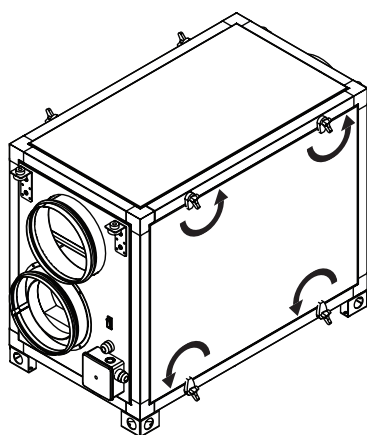

2.

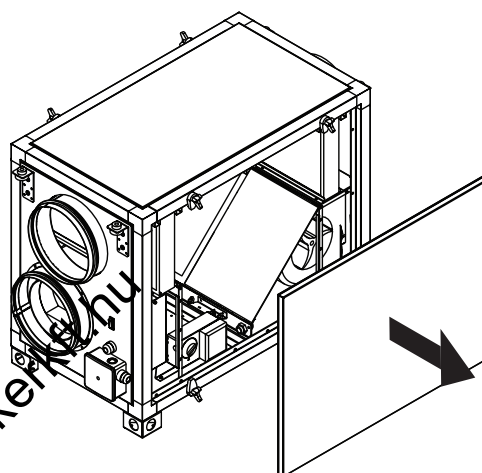

3.

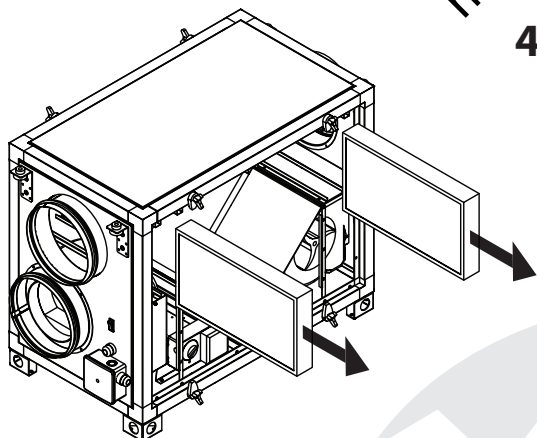

4.

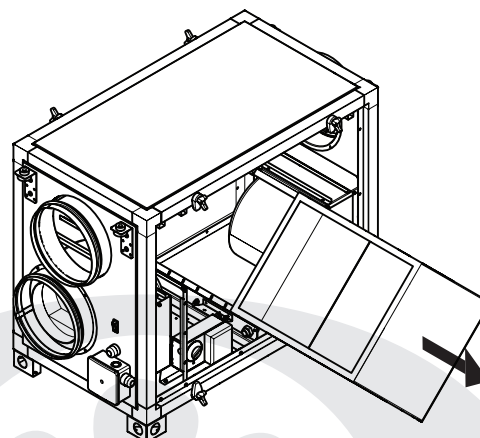

3. Fan maintenance (once a year).

Even regular technical maintenance of the filters may not completely prevent dirt accumulation in the fans which reduces the fan capacity. Clean the fans with rags or a soft brush. Do not use water, aggressive solvents or sharp objects as they may damage the impeller.

4. Technical maintenance of condensate drainage system (once a year).

The condensate drainage (drain line) may get clogged by dirt and dust particles contained in the exhaust air. Check the drain line operation by filling the drain pan under the unit with water, clean the U-trap and the drain line, if necessary.

5. Technical maintenance of the supply grille (twice a year).

The supply duct grille may get clogged with leaves and other objects reducing the unit performance and supply air delivery. Check the supply duct grill twice a year and clean it as required.

6. Technical maintenance of air duct system (every 5 years).

Even regular fulfilling of all the prescribed above maintenance operations may not completely prevent dirt accumulation in the air ducts which reduces the unit capacity. The air duct maintenance includes their periodic cleaning or replacement.

7. Technical maintenance of the exhaust louver shutters and supply diffusers (as required).

Remove the diffusers and the louver shutters and wash those with warm detergent solution. Do not change the position of the diffusers and the louver shutters.

■ FAULT HANDLING

Problem	Possible reasons	Fault handling
The fan(s) do(es) no start.	No power supply.	Make sure the power supply line is connected correctly, otherwise troubleshoot a connection error.
	Motor is jammed, the impeller blades are soiled.	Turn the unit off. Troubleshoot the motor jam and the impeller clogging. Clean the blades. Restart the unit.
Automatic circuit breaker tripping following the unit turning on.	Overcurrent resulted from short circuit in the electric circuit.	Turn the unit off. Contact the service centre.
Low air flow.	Low set fan speed.	Set higher speed.
	The filters, the fans or the heat exchanger are dirty.	Clean or replace the filters, clean the fans and the heat exchanger.
	The ventilation system components (air ducts, diffusers, louver shutters, grilles) are clogged or damaged.	Clean or replace the ventilation system components, such as air ducts, diffusers, louver shutters, grilles.
	The air dampers, diffusers or the louver shutters are closed.	Make sure the air dampers, diffusers or the louver shutters are fully opened.
Noise, vibration.	The impeller(s) is soiled.	Clean the impeller(s).
	The screw connection is loose.	Tighten the fan or casing screw connection against stop.
	No anti-vibration connectors.	Install anti-vibration connectors (available upon separate order).
Water leakage.	The drain line is clogged, damaged or wrong mounted.	Clean the drain line, if necessary. Check the drain line slant, inspect the U-trap and make sure the drain line is equipped with frost protection.

■ STORAGE AND TRANSPORTATION RULES

Store the unit in the manufacturer's original packing box in a dry closed ventilated premise with temperature range from +5 °C to +40°C.

Vapours or particles which can cause corrosion or damage the insulation or connection tightness are not allowed in the storage environment.

Use hoist machinery for handling and transportation to prevent possible mechanical damages of the unit. Fulfil the requirements for transportation of the specified cargo type.

Use any vehicle types for the unit transportation provided that it is protected against mechanical or weather damage.

Avoid any mechanical shocks and strokes during handling operations.

■ MANUFACTURER'S WARRANTY

The manufacturer hereby warrants normal operation of the unit over the period of 24 months from the retail sale date provided the user's observance of the transportation, storage, installation and operation regulations.

Should any malfunctions occur during the unit operation due to manufacturer's fault during the warranty period the user is entitled to elimination of faults by means of warranty repair performed by the manufacturer.

The warranty repair includes work specific to elimination of faults in the unit operation to ensure its intended use by the user within the warranty period. The faults are eliminated by means of replacement or repair of the complete unit or the faulty part thereof.

The warranty repair does not include:

- routine maintenance;
- unit installation / dismantling;
- unit setup.

To benefit from warranty repair the user must provide the unit, the user's manual with stamped sale date and the payment document certifying the purchase.

The unit model must comply with the one stated in the user's manual.

Contact the Seller for warranty service.

The manufacturer's warranty does not apply to the following cases:

- user's failure to provide the unit with the entire delivery package as stated in the user's manual or with missing component parts previously dismantled by the user;
- mismatch of the unit model and make with the respective details stated on the unit packing and in the user's manual;
- user's failure to ensure timely technical maintenance of the unit;
- external damage to the casing (excluding external modifications of the unit as required for its installation) and the internal components of the unit;
- alteration of the unit design or engineering changes of the unit;
- replacement and use of the unit assemblies, parts and components not approved by the manufacturer;
- unit misuse;
- user's violation of the unit installation regulations;
- user's violation of the unit control regulations;
- unit connection to the power mains with a voltage different from the one stated in the user's manual;
- unit breakdown due to voltage surges in the power mains;
- user's discretionary repair of the unit;
- unit repair performed by any persons not authorized by the manufacturer;
- expiry of the unit warranty period;
- user's violation of the established regulations specific to the unit transportation;
- user's violation of the unit storage regulations;
- wrongful acts against the unit committed by third persons;
- unit breakdown due to circumstances of insuperable force (fire, flood, earthquake, war, hostilities of any kind or blockades);
- missing seals if provided by the user's manual;
- failure to provide the user's manual with the sale date stamp;
- missing payment document certifying the unit purchase.



FOLLOWING THE REGULATIONS STIPULATED HEREIN WILL ENSURE A LONG AND TROUBLE-FREE OPERATION OF THE UNIT.



USERS' CLAIMS SHALL BE A SUBJECT TO REVIEW ONLY UPON PRESENTATION OF THE UNIT, THE PAYMENT DOCUMENT AND THE USER'S MANUAL WITH THE SALE DATE STAMP.

■ ACCEPTANCE CERTIFICATE

Product Type	Heat recovery air handling unit
Model	VUT_____H
Serial Number	
Manufacturing Date	
<p>We hereby declare that the product complies with the essential protection requirements of Electromagnetic Council Directive 2004/108/EC, 89/336/EEC and Low Voltage Directive 2006/95/EC, 73/23/EEC and CE-marking Directive 93/68/EEC on the approximation of the laws of the Member States relating to electromagnetic compatibility. This certificate is issued following test carried out on samples of the product referred to above.</p>	
Quality Inspector's Stamp	

■ SELLER INFORMATION

Shop name	
Address	
Phone number	
E-mail	
Sales date	
<p>This is to certify delivery of the complete unit with the user's manual. The warranty terms are acknowledged and accepted.</p>	
Customer's signature	

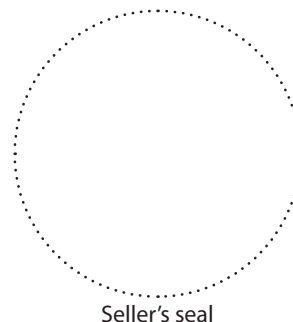

Seller's seal

■ CONNECTION CERTIFICATE

<p>VUT ___ H heat recovery air handling unit has been connected to power mains pursuant to the requirements stated in the present user's manual.</p>	
Company name	
Address	
Phone number	
Installation technician's full name	
Installation date:	Signature:
<p>This is to certify that the works specific to the unit installation has been performed in accordance with all the applicable provisions of local and national construction, electrical and technical codes and standards. The unit operates normally as intended by the manufacturer.</p>	
Signature:	

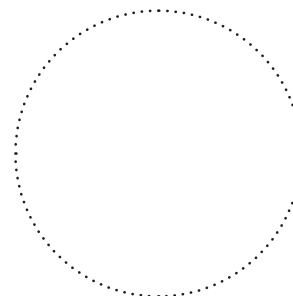

Installation technician's
company seal

■ WARRANTY CARD

Product type	Heat recovery air handling unit
Model	VUT_____H
Serial number	
Manufacturing date	
Sales date	
Warranty period	
Sales company	

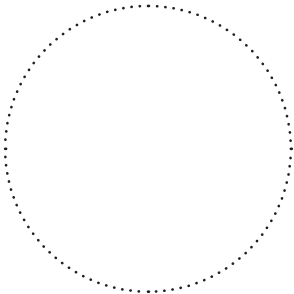

Seller's seal

■ NOTES

mepokerkft.hu



